

1. Features

- $R_{DS(ON)}=2.1m\Omega(\text{typ.})@V_{GS}=10V$
- Very Low On-resistance $R_{DS(ON)}$
- Low C_{rss}
- Fast switching
- 100% avalanche tested
- Improved dv/dt capability

2. Applications

- PWM Application
- Power Management
- Load switch

3. Symbol



TO-252

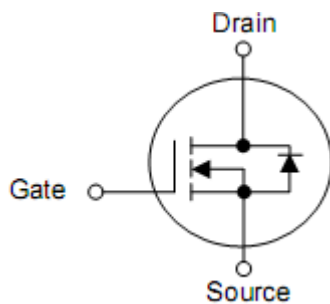

Pin	Function
1	Gate
2	Drain
3	Source

4. Ordering Information

Part Number	Package	Brand
KND2803S	TO-252	KIA

5. Absolute maximum ratings

$T_C=25^{\circ}\text{C}$ unless otherwise noted

Parameter	Symbol	Rating	Units	
Drain-source voltage	V_{DSS}	30	V	
Continuous drain current	$T_C=25^{\circ}\text{C}$	I_D	150	A
	$T_C=100^{\circ}\text{C}$	I_D	82	A
Pulsed drain current -Pulsed ¹⁾	I_{DM}	360	A	
Gate-source voltage	V_{GS}	± 20	V	
Single pulse avalanche energy ²⁾	E_{AS}	480	mJ	
Power dissipation($T_C=25^{\circ}\text{C}$)	P_D	48	W	
Operating junction and storage temperature range	T_J, T_{STG}	-55 to 150	$^{\circ}\text{C}$	
Maximum lead temperature for soldering purposes, 1/8" from case for 5 seconds	T_L	300	$^{\circ}\text{C}$	

*Drain current limited by maximum junction temperature.

6. Thermal characteristics

Parameter	Symbol	Rating	Unit
Thermal resistance junction-case	$R_{\theta JC}$	2.6	$^{\circ}\text{C/W}$

7. Electrical characteristics

(T_C=25°C unless otherwise noted)

Parameter	Symbol	Test Conditions	Min	Typ	Max	Units
Drain-source breakdown voltage	BV _{DSS}	V _{GS} =0V, I _D =250uA	30	-	-	V
Drain-source leakage current	I _{DSS}	V _{DS} =30V, V _{GS} =0V	-	-	1	uA
		V _{DS} =24V, T _C =125°C	-	-	50	uA
Gate-source forward leakage	I _{GSS}	V _{GS} =±20V, V _{DS} =0V	-	-	±100	nA
Gate threshold voltage	V _{GS(TH)}	V _{DS} =V _{GS} , I _D =250uA	1.0	1.6	2.2	V
Drain-source on-resistance	R _{DS(on)}	V _{GS} =10V, I _D =20A	-	2.1	2.8	mΩ
		V _{GS} =4.5V, I _D =10A	-	2.8	3.8	mΩ
Input capacitance	C _{iss}	V _{DS} =25V, V _{GS} =0V f=1MHz	-	5705	-	pF
Output capacitance	C _{oss}		-	530	-	pF
Reverse transfer capacitance	C _{rss}		-	500	-	pF
Turn-on delay time	t _{d(on)}	V _{GS} =10V, V _{DS} =15V, R _L =3.3Ω, I _D =30A ³⁾	-	12	-	ns
Rise time	t _r		-	15	-	ns
Turn-off delay time	t _{d(off)}		-	78	-	ns
Fall time	t _f		-	30	-	ns
Total gate charge(10V)	Q _g	V _{DS} =15V, I _D =40A V _{GS} =10V ³⁾	-	112	-	nC
Gate-source charge	Q _{gs}		-	25	-	nC
Gate-drain charge	Q _{gd}		-	28	-	nC
Maximum Continuous Drain-Source Diode Forward Current	I _S	—	-	-	140	A
Maximum Pulsed Drain-Source Diode Forward Current	I _{SM}	—	-	-	360	A
Drain to Source Diode Forward Voltage	V _{SD}	V _{GS} =0V, I _{SD} =20A, T _J =25°C	-	-	1.2	VS
Body Diode Reverse Recovery Time	t _{rr}	I _F =30A, di/dt=100A/us	-	-	22	nS
Body Diode Reverse Recovery Charge	Q _{rr}		-	-	13	nC

Note:

- 1) Repetitive Rating: Pulse Width Limited by Maximum Junction Temperature
- 2) EAS condition: T_J=25°C, V_{DD}=20V, V_G=10V, R_G=25Ω, L=0.5mH.
- 3) Pulse Test: Pulse Width≤300us, Duty Cycle≤0.5%

8. Typical operating characteristics

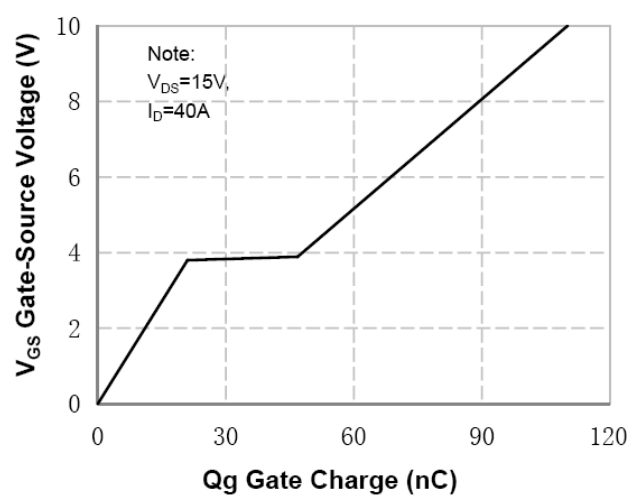
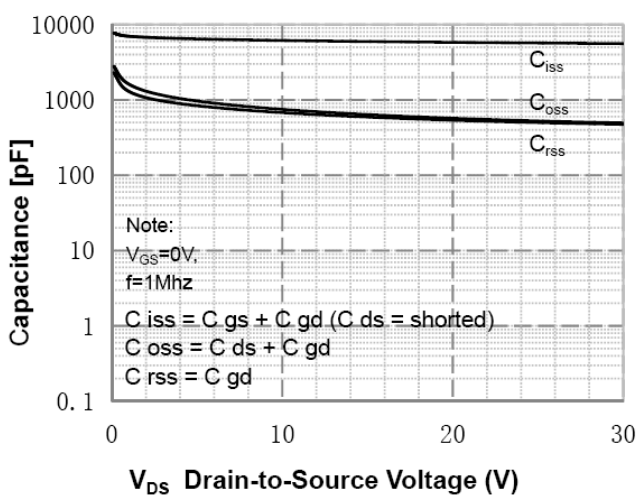
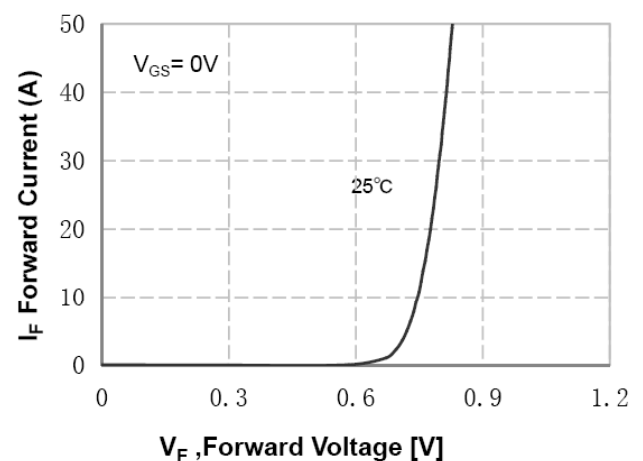
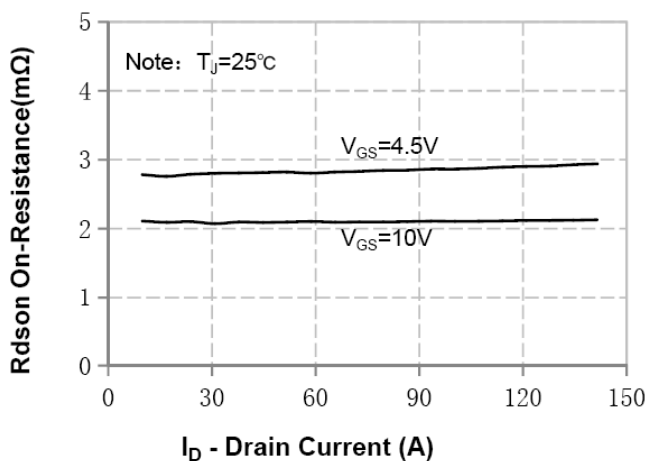
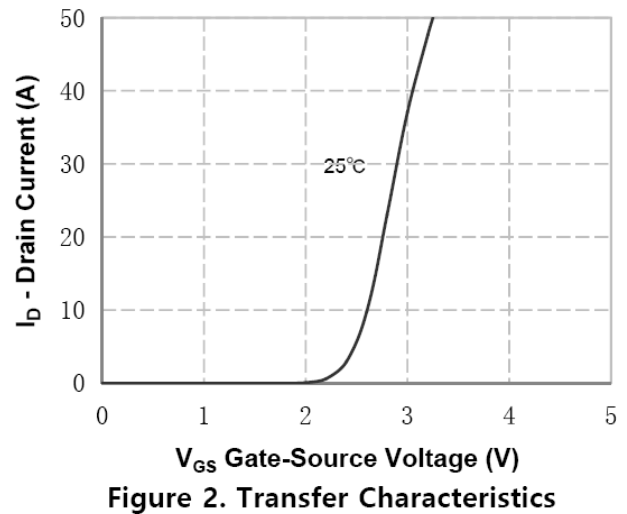
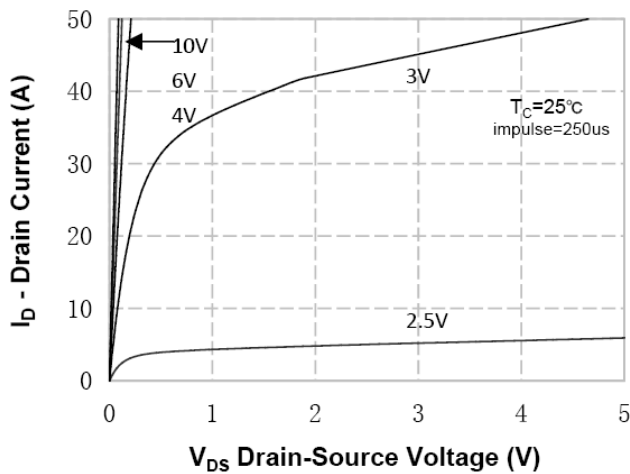

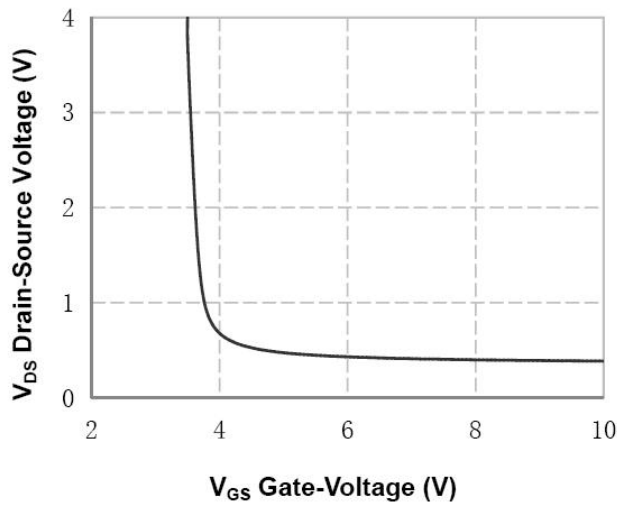

Figure 7. Vds Drain-Source Voltage vs Gate Voltage

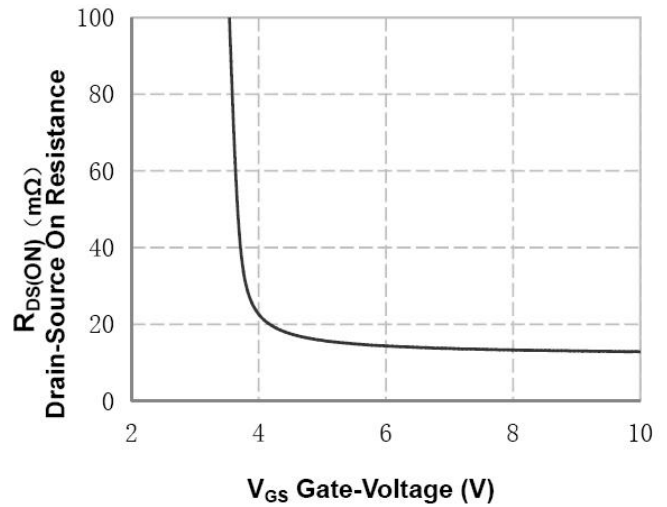

Figure 8. On-Resistance vs Gate Voltage

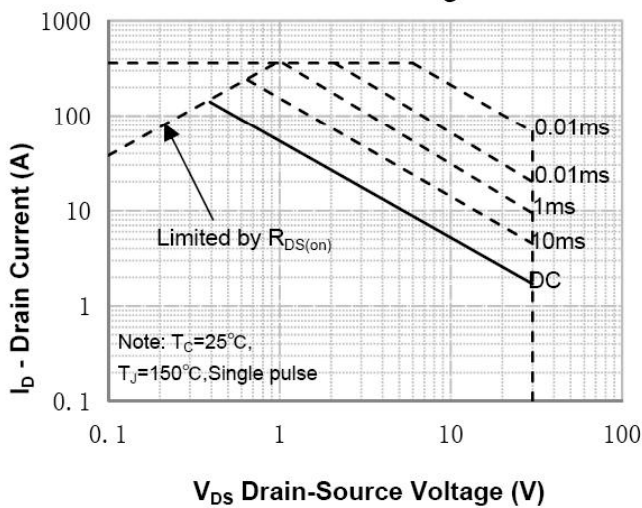

Figure 9. Maximum Safe Operating Area

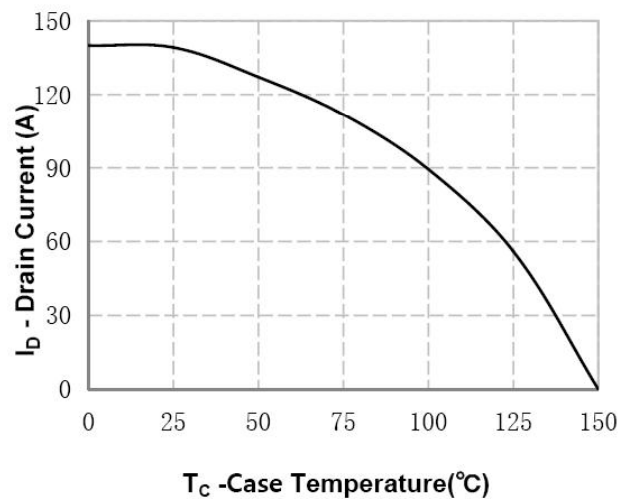

Figure 10. Maximum Continuous Drain Current vs Case Temperature

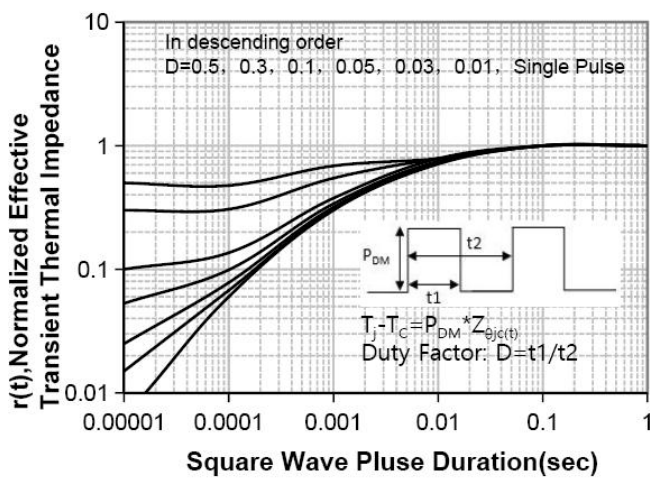
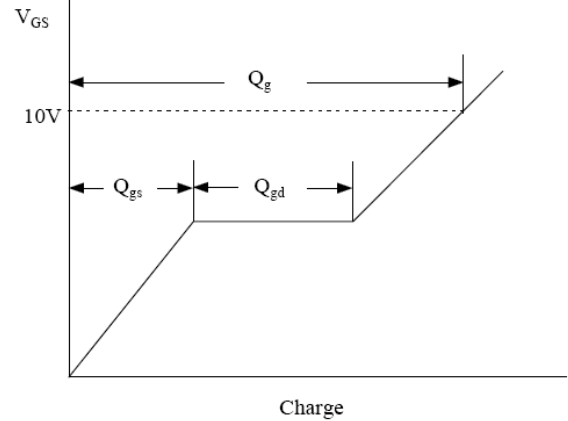
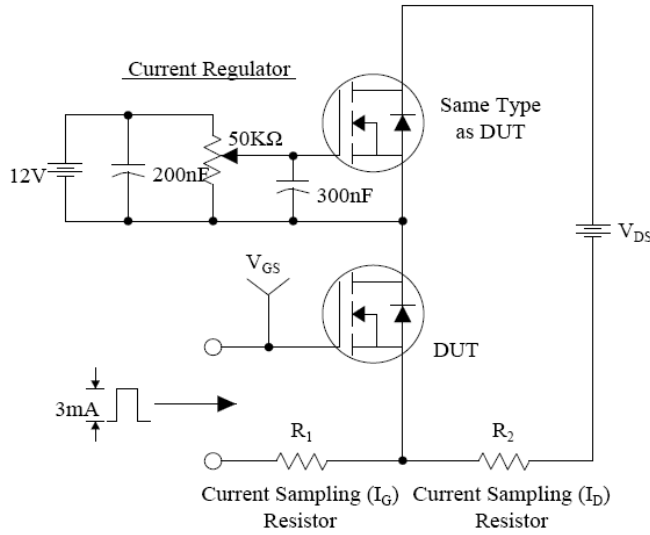

Figure 11. Transient Thermal Response Curve

9. Test Circuits and Waveforms

Gate Charge Test Circuit & Waveform



Resistive Switching Test Circuit & Waveforms

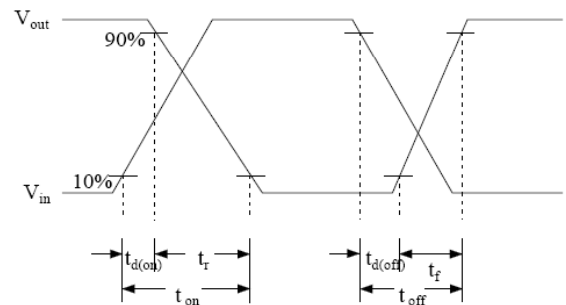
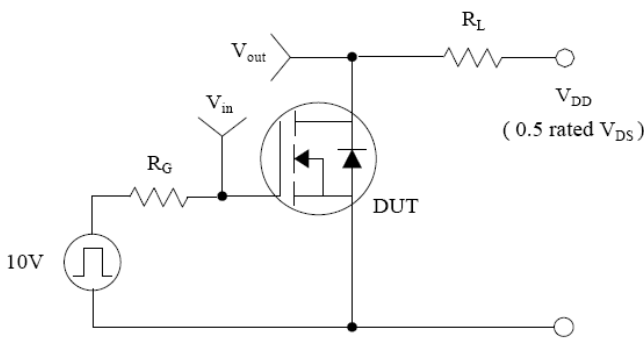

Unclamped Inductive Switching Test Circuit & Waveforms

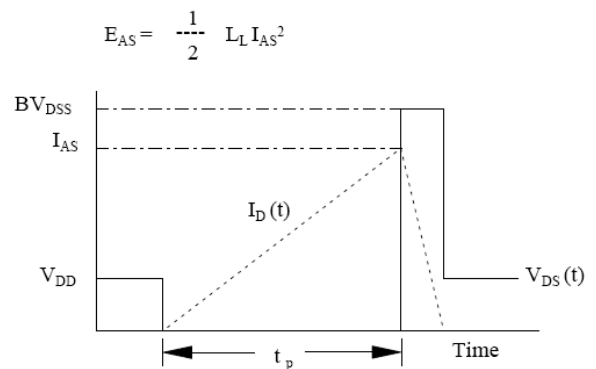
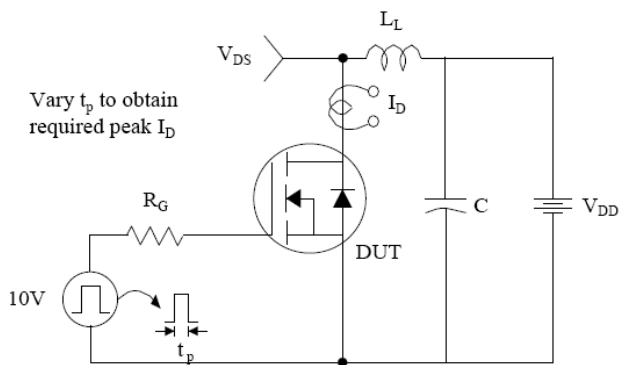

Peak Diode Recovery dv/dt Test Circuit & Waveforms

