

1. Description

This Power MOSFET is produced using KIA advanced planar stripe DMOS technology. This advanced has been especially tailored to minimize on-state resistance, provide superior switching performance, and withstand high energy pulse in the avalanche and commutation mode. These devices are well suited for high efficiency switched mode power supplies, active power factor correction based on half bridge topology.

2. Features

- n $R_{DS(on)}=0.85\Omega @ V_{GS}=10V$
- n Low gate charge (typical 63nC)
- n High ruggedness
- n Fast switching capability
- n Avalanche energy specified
- n Improved dv/dt capability
- n ESD improved capability

3. Pin configuration

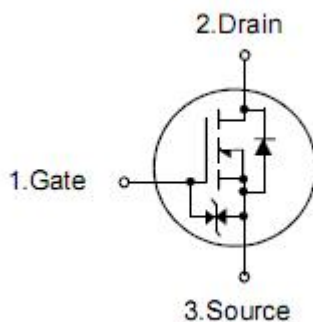
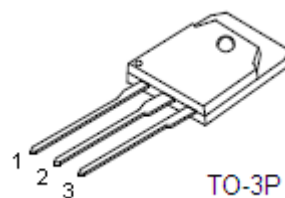

Pin	Function
1	Gate
2	Drain
3	Source

4. Absolute maximum ratings

(T_C= 25 °C , unless otherwise specified)

Parameter	Symbol	Ratings	Units
Drain-source voltage	V _{DSS}	800	V
Gate-source voltage	V _{GSS}	±25	V
Drain current continuous	I _D	T _C =25°C	10
		T _C =100°C	6
Drain current pulsed (note1)	I _{DP}	40	A
Avalanche energy	Repetitive (note1)	E _{AR}	30.5
	Single pulse (note2)	E _{AS}	350
Peak diode recovery dv/dt (note 3)	dv/dt	4.5	V/ns
Total power dissipation	P _D	T _C =25°C	305
		derate above 25°C	2.44
Junction temperature	T _J	+150	°C
Storage temperature	T _{STG}	-55~+150	°C

5. Thermal characteristics

Parameter	Symbol	Ratings	Units
Thermal resistance,junction-ambient	R _{thJA}	62.5	°C/W
Thermal resistance,case-to-sink typ.	R _{thCS}	-	
Thermal resistance,Junction-case	R _{thJC}	0.4	

6. Electrical characteristics

($T_J=25^\circ\text{C}$, unless otherwise specified)

Parameter	Symbol	Conditions	Min	Typ	Max	Units
Off characteristics						
Drain-source breakdown voltage	BV_{DSS}	$V_{GS}=0V, I_D=250\mu A$	800	-	-	V
Zero gate voltage drain current	I_{DSS}	$V_{DS}=800V, V_{GS}=0V$	-	-	1	μA
		$V_{DS}=640V, T_C=125^\circ C$	-	-	10	μA
Gate-body leakage current	Forward	I_{GSS}	-	-	10	μA
	Reverse					
			-	-	-10	μA
Breakdown voltage temperature coefficient	$\Delta BV_{DSS}/\Delta T_J$	$I_D=250\mu A$	-	0.8	-	$V/^\circ C$
On characteristics						
Gate threshold voltage	$V_{GS(th)}$	$V_{DS}=V_{GS}, I_D=250\mu A$	2.0	-	4.0	V
Static drain-source on-resistance	$R_{DS(on)}$	$V_{DS}=10V, I_D=5A$	-	0.85	1.1	Ω
Dynamic characteristics						
Input capacitance	C_{iss}	$V_{DS}=25V, V_{GS}=0V, f=1MHz$	-	2230	-	pF
Output capacitance	C_{oss}		-	135	-	pF
Reverse transfer capacitance	C_{rss}		-	74	-	pF
Switching characteristics						
Turn-on delay time	$t_{d(on)}$	$V_{DD}=400V, I_D=10A, R_G=25\Omega$ (note4,5)	-	25	-	ns
Rise time	t_r		-	35	-	ns
Turn-off delay time	$t_{d(off)}$		-	225	-	ns
Fall time	t_f		-	145	-	ns
Total gate charge	Q_g	$V_{DS}=640V, I_D=10A, V_{GS}=10V$ (note4,5)	-	63	-	nC
Gate-source charge	Q_{gs}		-	10	-	nC
Gate-drain charge	Q_{gd}		-	25	-	nC
Drain-source diode characteristics						
Drain-source diode forward voltage	V_{SD}	$V_{GS}=0V, I_D=10A$	-	-	1.4	V
Continuous drain-source current	I_{SD}		-	-	9	A
Pulsed drain-source current	I_{SM}		-	-	36	A
Reverse recovery time	t_{rr}	$I_{SD}=10A, di_{SD}/dt=100A/\mu s$ (note4)	-	850	-	ns
Reverse recovery charge	Q_{rr}		-	10	-	μC

Note: 1 Repetitive rating: pulse width limited by maximum junction temperature

2. $L=6.3mH, I_{AS}=10A, V_{DD}=50V, R_G=25\Omega$, starting $T_J=25^\circ C$
3. $I_{SD}\leq 9A, di/dt\leq 200A/\mu s, V_{DD}\leq BV_{DSS}$, starting $T_J=25^\circ C$
4. Pulse test: pulse width $\leq 300\mu s$, duty cycle $\leq 2\%$
5. Essentially independent of operating temperature

7. Test circuits and waveforms

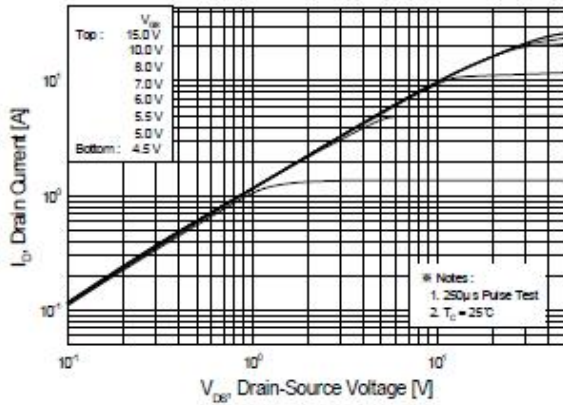

Figure 1. On-Region Characteristics

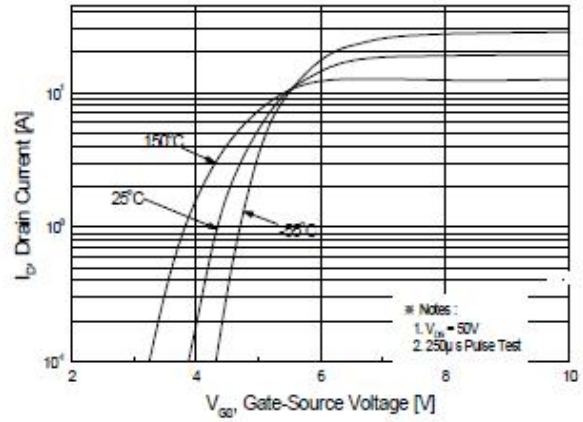

Figure 2. Transfer Characteristics

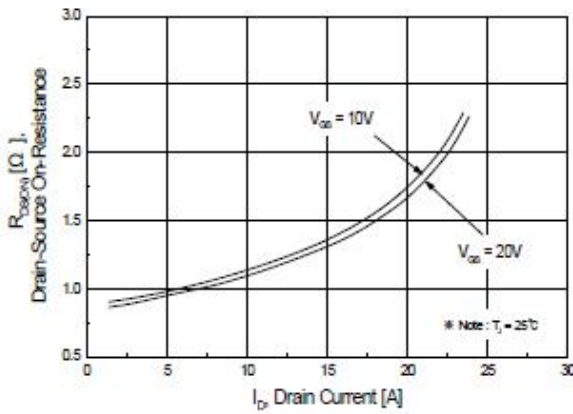

Figure 3. On-Resistance Variation vs Drain Current and Gate Voltage

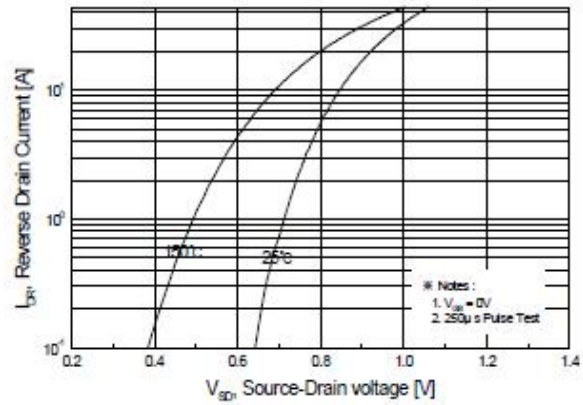

Figure 4. Body Diode Forward Voltage Variation with Source Current and Temperature

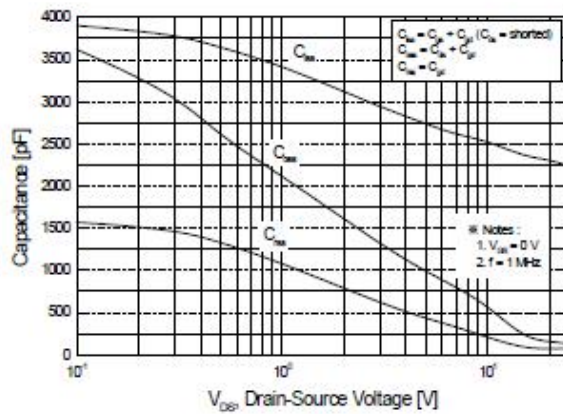

Figure 5. Capacitance Characteristics

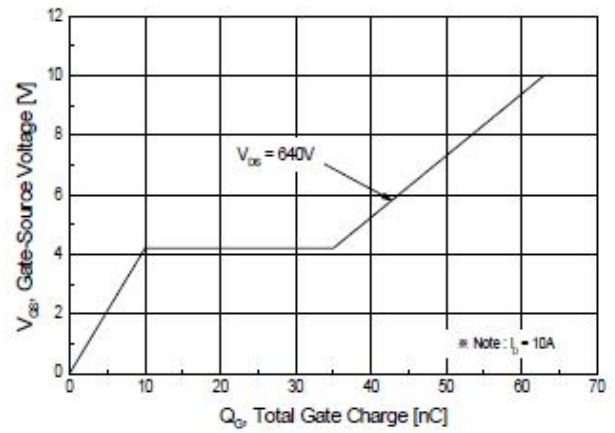

Figure 6. Gate Charge Characteristics

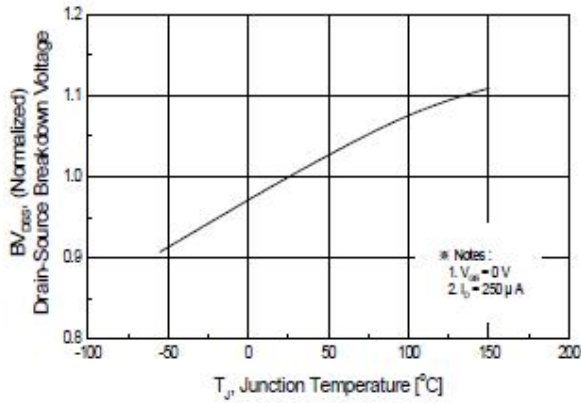

Figure 7. Breakdown Voltage Variation vs Temperature

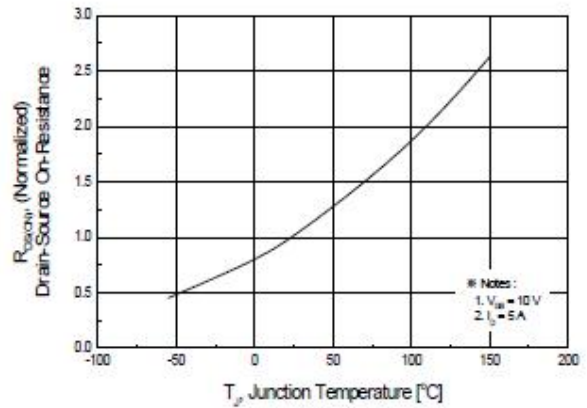

Figure 8. On-Resistance Variation vs Temperature

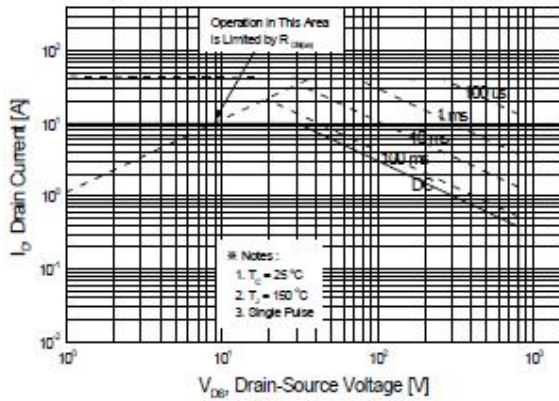

Figure 9. Maximum Safe Operating Area

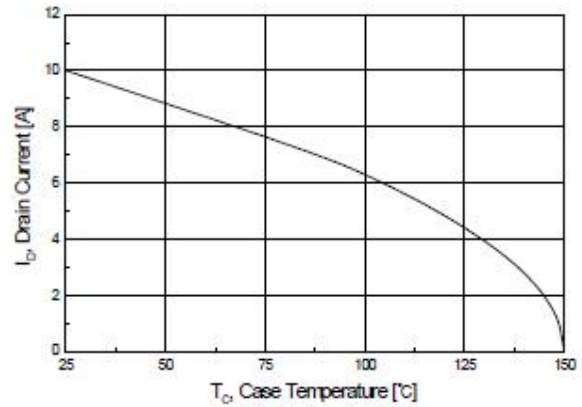

Figure 10. Maximum Drain Current vs Case Temperature

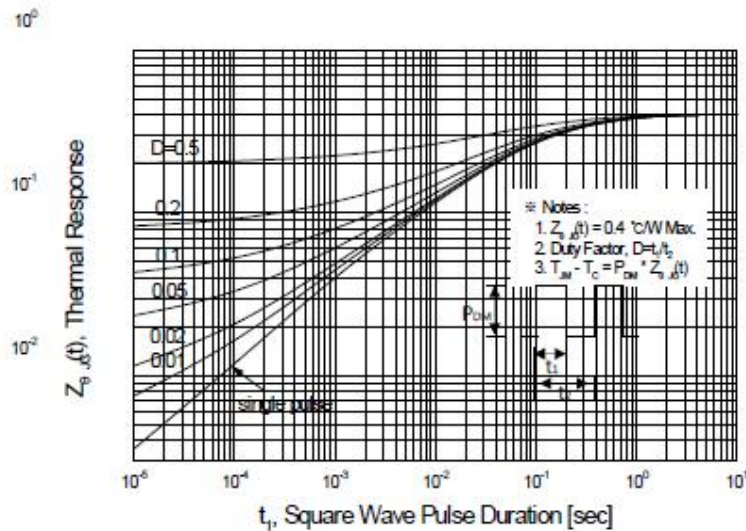

Figure 11. Transient Thermal Response Curve